

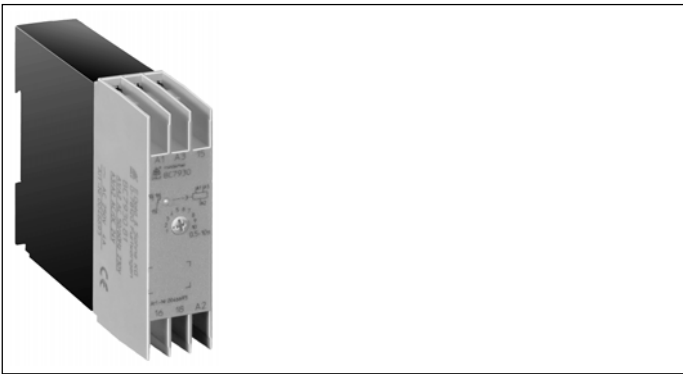

Time Control Relays

Timer BC 7930, operate delay minitimer

0221544



- According to DIN EN 61 812-1
- Time delay between 0,05 s ... 10 h
- Repeat accuracy $\leq 0,5 \% + 10 \text{ ms}$
- Dual voltage supply
- LED indicator for contact position
- 1 changeover contact
- Width 22,5 mm

Function diagram

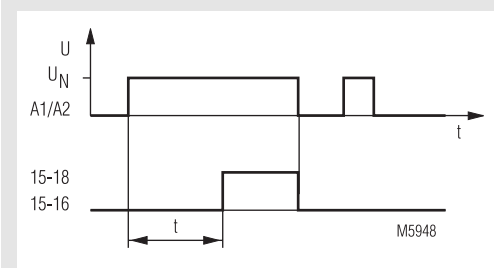

Circuit diagram

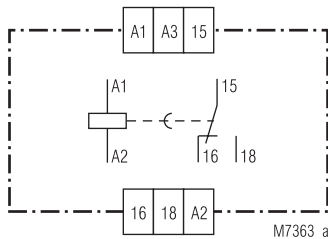

Approvals and marking

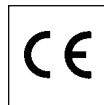

Applications

Time dependent controllers

Indication

LED: on when output relay activated (contacts 15-18 are closed)

Standard type

BC 7930.81 AC/DC 24 V + AC 230 V 5 ... 100 s
 Article number: 0046696 stock item
 • Output: 1 changeover contact
 • Nominal voltage U_N : AC/DC 24 V + AC 230 V
 • Time range: 5 ... 100 s

Technical data

Time circuit

| Time ranges: | 0,05 ... 1 s | 0,5 ... 10 min. |
|--------------|--------------|-----------------|
| | 0,15 ... 3 s | 1,5 ... 30 min. |
| | 0,5 ... 10 s | 3 ... 60 min. |
| | 1,5 ... 30 s | 0,15 ... 3 h |
| | 5 ... 100 s | 0,5 ... 10 h |
| | 15 ... 300 s | |

Time setting: stepless 1:20
Recovery time: $\leq 100 \text{ ms}$
Repeat accuracy: $\leq 0,5 \% + 10 \text{ ms}$
Voltage influence: $\leq 1 \%$
Temperature influence: $\leq 0,25 \% / K$

Input

Nominal voltage U_N : AC/DC 24 V¹⁾ + AC 230 V²⁾
 AC/DC 24 V¹⁾ + AC 110 ... 127 V²⁾
 AC/DC 24 V¹⁾ + AC 42 V²⁾
 AC/DC 12 V

¹⁾ at terminals A3-A2

²⁾ at terminals A1-A2

Voltage range: 0,8 ... 1,1 U_N at AC
 0,9 ... 1,25 U_N at DC

Nominal consumption: AC: 4 VA
 DC: 0,4 W

Nominal frequency: 50 / 60 Hz

Frequency range: $\pm 5 \% f_N$

Release voltage: 15 % U_N

Technical data

Output

Contacts:

BC 7930.81: 1 changeover contact

Thermal current I_{th} : 4 A

Switching capacity

to AC 15

NO contact: 3 A / AC 230 V EN 60 947-5-1

NC contact: 1 A / AC 230 V EN 60 947-5-1

Electrical life EN 60 947-5-1

to AC 15 at 1 A, AC 230 V: $1,5 \times 10^5$ switching cycles

Short circuit strength

max. fuse rating: 4 A gL EN 60 947-5-1

Mechanical life: 10^8 switching cycles

General data

Operating mode: Continuous operation

Temperature range: - 20 ... + 60°C

Clearance and creepage distances

overvoltage category /
contamination level 4 kV / 2 DIN VDE 0110-1 (04.97)

EMC

Electrostatic discharge: 8 kV (air) EN 61 000-4-2

HF irradiation: 10 V/m EN 61 000-4-3

Fast transients: 4 kV EN 61 000-4-4

Surge voltages

between

wires for power supply: 1 kV EN 61 000-4-5

between wire and ground: 4 kV EN 61 000-4-5

Interference suppression: Limit value class B EN 55 011

Degree of protection: Housing: IP 40 EN 60 529

Terminals: IP 20 EN 60 529

Housing: Thermoplastic with V0 behaviour
according to UL subject 94

Vibration resistance: Amplitude 0,35 mm EN 60 068-2-6

frequency 10 ... 55 Hz

Climate resistance: 20 / 60 / 04 EN 60 068-1

Terminal designation: EN 50 005

Wire connection: 2 x 2,5 mm² solid or
2 x 1,5 mm² stranded wire with sleeve
DIN 46 288

Wire fixing: Flat terminals with self-lifting

clamping piece EN 60 999

Mounting: DIN rail EN 50 022

Weight: 80 g

Ordering example

BC 7930 .81 AC/DC 24 + AC 230 V 50 / 60 Hz 10 s

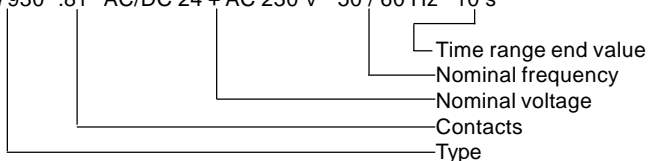

Time range end value
Nominal frequency
Nominal voltage
Contacts
Type

Dimensions

Width x height x depth: 22,5 x 84 x 97 mm

Time relay BC 7933, release delay minitimer

0225284

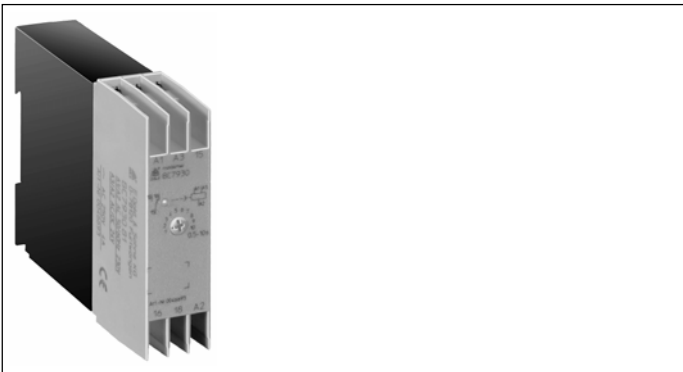

- According to DIN EN 61 812-1
- Time ranges between 0,05 s and 10 h
- Settable release delay
- With auxiliary voltage
- Wide voltage range AC 110 ... 240 V
- Control input operated with nominal voltage, No voltage free contact necessary
- LED indicator for status of contact
- 1 changeover contact
- Width 22,5 mm

Function diagram

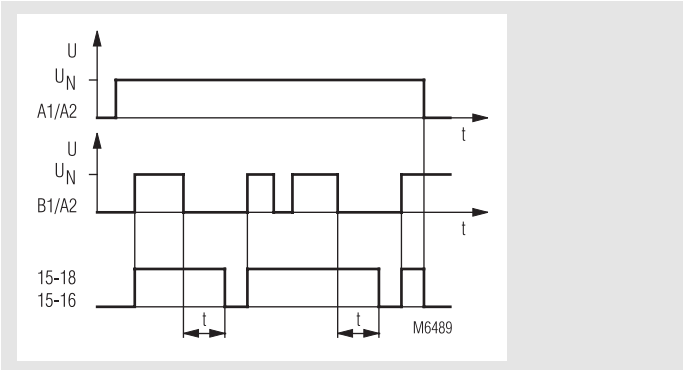

Circuit diagram

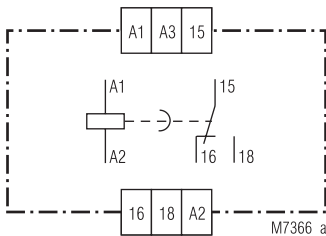

Approvals and marking



Applications

Time-dependent control circuits

Indicators

yellow LED: on, when output relay activated (contact 15 - 18 closed)

Notes

The relay needs a supply voltage continuously connected to A1-A2. At relays with auxiliary supply < AC 180 V the control input must not be operated before the auxiliary supply is present for at least 150 ms. In this case also the recovery time after time delay is 150 ms.

Standard type

BC 7933.81 AC 110 ... 240 V 50/60 Hz 0,5 ... 10 s
 Article number: 0047804
 • Output: 1 changeover contact
 • Nominal voltage U_N : AC 110 ... 240 V
 • Time range: 0,5 ... 10 s

Technical data

Time circuit

| | | |
|---------------------|--------------|--------------|
| Time ranges: | 0,05 ... 1 s | 0,5 ... 10 m |
| | 0,15 ... 3 s | 1,5 ... 30 m |
| | 0,5 ... 10 s | 0,15 ... 3 h |
| | 1,5 ... 30 s | 0,5 ... 10 h |
| | 5 ... 100 s | |
| | 15 ... 300 s | |

Time setting: infinitely variable 1:20
Min. closing time: (Control input B1)

AC: 15 ms
 DC: 5 ms

Recovery time: < 50 ms
Repeat accuracy: $\leq 0,5 \% + 10 \text{ ms}$
Voltage influence: $\leq 1 \%$
Temperature influence: $\leq 0,25 \% / K$

Input

Nominal voltage U_N : (A1/A2 and B1/A2)
 AC 110 ... 240 V
 AC 42 V
 AC/DC 24 V
Voltage range: AC: 0,8 ... 1,1 U_N
 DC: 0,9 ... 1,25 U_N
Nominal consumption: AC: 4 VA
 DC: 0,4 W

Technical data

Nominal frequency: AC: 50 / 60 Hz
Frequency range: AC: 45 ... 65 Hz
Reset voltage: (Control input B1)
 $\geq 15 \% U_N$

Output

Contacts:
 BC 7933.81: 1 changeover contact
Thermal current I_{th} :
 4 A
Switching capacity
 to AC 15
 NO contact: 3 A / AC 230 V EN 60 947-5-1
 NC contact: 1 A / AC 230 V EN 60 947-5-1
Electrical contact life
 to AC 15 at 1 A, AC 230 V: $1,5 \times 10^5$ switching cycles
Short circuit strength
max. fuse rating: 4 A gL EN 60 947-5-1
Mechanical life: 10^8 switching cycles

General data

Operating mode: Continuous operation
Temperature range: - 20 ... + 60°C
Clearance and creepage distances
 overvoltage category /
 contamination level: 4 kV / 2 DIN VDE 0110-1 (04.97)
EMC
 Electrostatic discharge: 8 kV (air) EN 61 000-4-2
 HF irradiation: 10 V/m EN 61 000-4-3
 Fast transients: 4 kV EN 61 000-4-4
 Surge voltages
 between
 wires for power supply: 1 kV EN 61 000-4-5
 between wire and ground: 4 kV EN 61 000-4-5
 Interference suppression: Limit value class B EN 55 011
Degree of protection: Housing: IP 40 EN 60 529
 Terminals: IP 20 EN 60 529
Housing: Thermoplastic with V0 behaviour
 according to UL subject 94
Vibration resistance: Amplitude 0,35 mm EN 60 068-2-6
 frequency 10 ... 55 Hz
Climate resistance: 20 / 60 / 04 EN 60 068-1
Terminal designation: EN 50 005
Wire connection: 2 x 2,5 mm² solid or
 2 x 1,5 mm² stranded wire with sleeve
 DIN 46 228-1/-2
Wire fixing: Flat terminals with self-lifting
 clamping piece EN 60 999
Mounting: DIN rail EN 50 022
Weight: 80 g

Ordering example

BC 7933 .81 AC 110 ... 240 V 50 / 60 Hz 10 s

Time delay
 Nominal frequency
 Nominal voltage
 Contact
 Type

Dimensions

Width x height x depth: 22,5 x 84 x 97 mm

Connection example

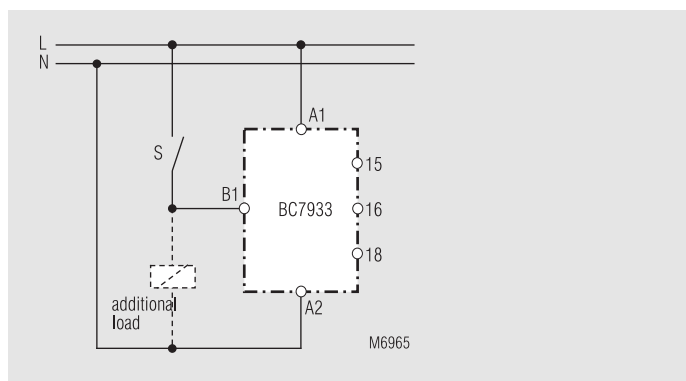

Time control technique



Time relay MK 9906, AA 9906, operate delayed minitimer

0221562



- According to EN 61 812-1
- Time delay of 0,05 s ... 100 h
- Repeat accuracy $\leq \pm 0,5 \%$
- Adjustable on absolute scale
- MK 9906 as a 2-voltage version
- AA 9906/200 for AC/DC 24 ... 240 V
- Available with instantaneous contact
- LED indicators for operation and contact position
- Controllable by proximity sensors
- 2 changeover contacts
- Width 22, 5 mm

Function diagram

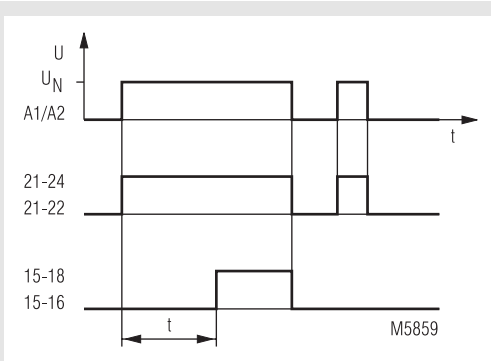

Approvals and marking

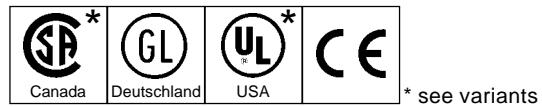

Application

Time-dependent controllers

Indicators

upper LED: on, when supply connected
 lower LED: on, when output relay active (contact 15-18 closed)

Standard types

MK 9906 AC/DC 24 V + AC 220 ... 240 V 0,5 ... 10 s
 Article number: 0044835 stock item
 • Output: 2 changeover contacts
 • Nominal voltage U_N : AC/DC 24 V + AC 220 ... 240 V

AA 9906.81 AC 230 V 0,5 ... 10 min.
 Article number: 0017124
 • Output: 1 changeover contact
 • Nominal voltage U_N : AC 230 V

Variants

- MK 9906.83:** AC 230 ... 240 V
3 changeover contacts
- MK 9906.81/007:** to be used as star-delta timer resetting time of contacts approx. 100 ms, AC 230 V, 1 changeover contact
- MK 9906.81/009:** With resetting time of 300 ms to bridge brief power failures, 1 changeover contact
Nominal voltage: AC 230 ... 240 V
Recovery time:
tw 50 / 100: ≤ 500 ms
- MK 9906.82/008:** DC 24 V, 2 changeover contacts
Make current:
 ≤ 100 mA, typ. at DC 24 V: 80 mA
Recovery time:
tw 50/100: ≤ 20 ms
(suitable to be controlled by reed contacts)
- MK 9906.82/60:** with CSA-approval, 2 changeover contacts
- MK 9906.82/61:** with UL-approval, 2 changeover contacts for AC/DC 24 ... 240 V at $-40^\circ\text{C} \dots +60^\circ\text{C}$ ambient temperature range
- AA 9906.___/200:** Voltage range: AC 19 ... 264 V
DC 19 ... 300 V

Circuit diagrams

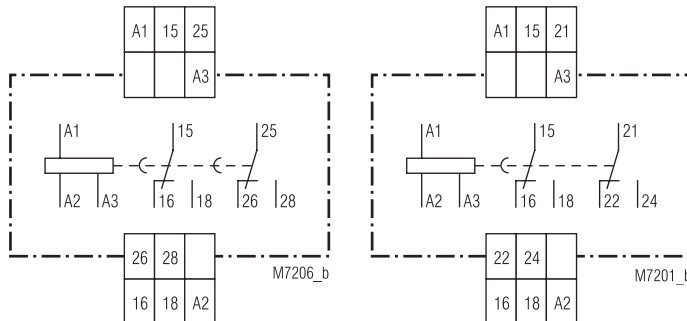

MK 9906.82

MK 9906.32

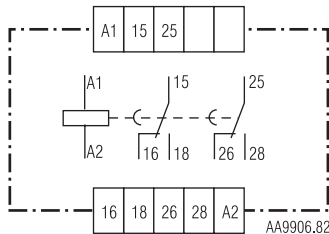

AA 9906.82

Pulse generator MK 7854 minitimer

022157/5

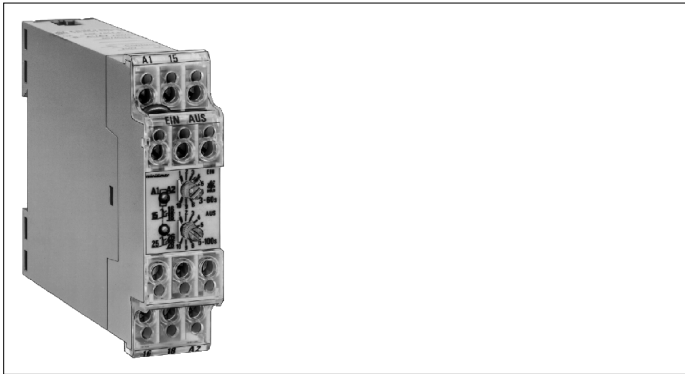

- According to DIN EN 61 812-1
- Independently selectable pulse and space times up to 30 h
- Repeat accuracy $\leq \pm 1 \%$
- Programmable: starts with pulse or space
- 2 LED displays for availability and contact position
- 2 changeover contacts
- Available with CSA approval
- Width 22,5 mm

Function diagram

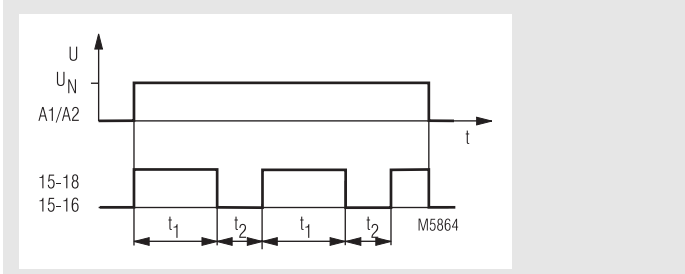

Circuit diagram

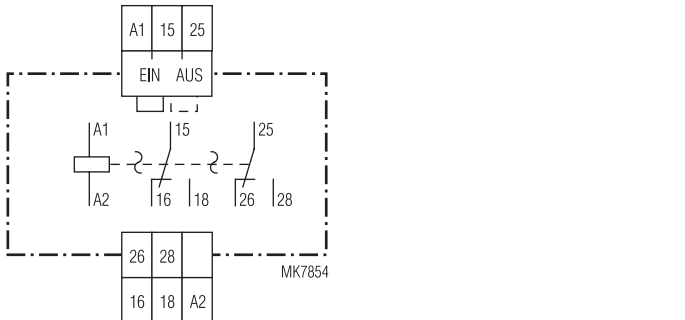

Approvals and marking



* see variants

Application

Time-dependent controllers

Indication

upper LED: on when operating voltage applied
lower LED: on when output relay activated (contacts 15-18 are closed)

Variants

MK 7854/10: Starts with space
MK 7854/60: with CSA-approval

Technical data

Time circuit

Time ranges:

| | |
|--------------|-----------------|
| 0,05 ... 1 s | 0,5 ... 10 min. |
| 0,15 ... 3 s | 3 ... 60 min. |
| 0,5 ... 10 s | 0,15 ... 3 h |
| 1,5 ... 30 s | 0,5 ... 10 h |
| 3 ... 60 s | 1,5 ... 30 h |
| 5 ... 100 s | |
| 15 ... 300 s | |

End ranges for pulse and space times can be selected in any combination

Time setting: stepless, on relative scale

Recovery time

tw 50 / 100: < 80 ms

Repeat accuracy:

$\leq \pm 1 \%$ of full-scale value

Voltage influence:

$\leq 1 \%$

Temperature influence:

< 0,1 % / K

Input

Nominal voltage U_N : AC 110, 127, 230, 240 V

AC/DC 24, 42 V

Voltage range: AC 0,8 ... 1,1 U_N

Nominal consumption: AC 1,5 VA

DC 24 V 0,6 W

DC 42 V 1,0 W

Nominal frequency: 50 / 60 Hz

Frequency range: $\pm 5 \%$ f_N

Technical data

Output

| | | |
|---|---------------------------------------|---------------------|
| Contacts: | 2 changeover contacts | |
| Release time of the contacts: | approx. 25 ms | |
| Thermal current I_{th}: | 5 A | |
| Switching capacity | | |
| to AC 15: | | |
| NO contact: | 3 A / AC 230 V | DIN VDE 0660 p. 200 |
| NC contact: | 2 A / AC 230 V | DIN VDE 0660 p. 200 |
| Electrical life | DIN VDE 0660 p. 200 | |
| to AC 15 at 3 A, AC 230 V: | 5 x 10 ⁵ switching cycles | |
| Permissible operating frequency: | 36 000 switching cycles / h | |
| Short circuit strength | | |
| max. fuse rating: | 4 A gL | DIN VDE 0660 |
| Mechanical life: | 30 x 10 ⁶ switching cycles | |

General data

| | | |
|--|--|-----------------------|
| Operating mode: | Continuous operation | |
| Temperature range: | - 20 ... + 60 °C | |
| Clearance and creepage distances | | |
| overvoltage category / contamination level: | 4 kV / 2 | DIN VDE 0110-1 (4.97) |
| EMC | | |
| Electrostatic discharge: | 8 kV (air) | EN 61 000-4-2 |
| HF irradiation: | 10 V / m | EN 61 000-4-3 |
| Fast transients: | 2 kV | EN 61 000-4-4 |
| Surge voltages: | 1 kV | EN 61 000-4-5 |
| Interference suppression: | Limit value class B | EN 55 011 |
| Degree of protection: | | |
| Housing: | IP 40 | DIN VDE 0470-1 |
| Terminals: | IP 20 | DIN VDE 0470-1 |
| Housing: | Thermoplastic with V0 behaviour to UL subject 94 | |
| Vibration resistance: | Amplitude 0,35 mm, frequency 10 ... 55 Hz, IEC 68-2-6 | |
| Climate resistance: | 20 / 60 / 04 | DIN EN 60 068-1 |
| Terminal designation: | DIN EN 50 005 | |
| Wire connection: | 2 x 1,5 mm ² solid or 2 x 1,0 mm ² stranded wire with sleeve DIN 46 288-1/-2/-3/-4 | |
| Wire fixing: | Flat terminals with self-lifting clamping piece DIN 46 206 and DIN 57 609 / VDE 0609 | |
| Mounting: | DIN rail | DIN EN 50 022 |
| Weight: | 165 g | |

Ordering example

| | |
|--|----------------------|
| MK 7854 /60 AC 230 V 50 / 60 Hz 30 s Ein / 3 h Aus | |
| | Time range end value |
| | Nominal frequency |
| | Nominal voltage |
| | Contact |
| | Type |

Dimensions

| | |
|-------------------------|-------------------|
| Width x height x depth: | 22,5 x 82 x 99 mm |
|-------------------------|-------------------|

Accessories

| | |
|--------------|---------------|
| ET 4752-143: | Marking plate |
|--------------|---------------|

Time control technique

Cyclic timer MK 7854N minitimer



- According to IEC/EN 61 812-1
- 8 time ranges from 0,05 s to 300 h selectable via rotational switches
- Impulse and break time separately adjustable
- Selectable start with impulse or break
- Voltage range AC/DC 12 ... 240 V
- Adjustment aid for quick setting of long time values
- Suitable for 2-wire proximity sensor control
- LED indicators for operation, contact position and time delay
- 2 changeover contacts
- As option 1 changeover contact instantaneously programmable
- As option connection of 2 remote potentiometers
- As option with time interruption / time adding input
- 22,5 mm width

Function diagram

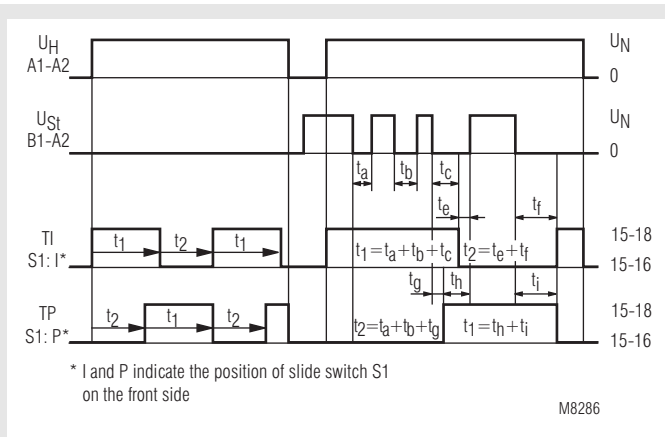

Approvals and marking

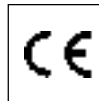

Application

Time-dependent controllers

Indicators

- | | |
|--------------------------------|--|
| green LED: | on when voltage connected |
| yellow LED "R/t": | shows status of output relay and time delay: |
| -Flashing (short on, long off) | output relay not active; |
| | time delay t2 (break time) |
| -Flashing (long on, short off) | output relay active; |
| | time delay t1 (pulse time) |

Circuit diagram

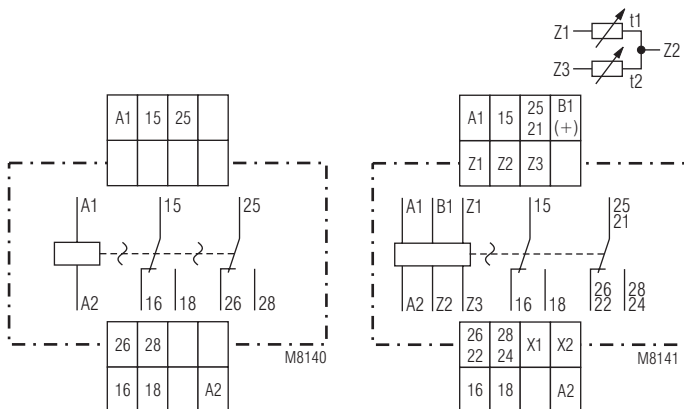

MK 7854N.82

MK 7854N.82/500

Notes

Adjustment assistance

The flashing period of the yellow LED is $1\text{ s} \pm 4\%$ and can be used to adjust the time. Especially on the lower end of scale and for long times it is suitable as the multiplication factors between the different time ranges are exact without tolerance.

Example:

The required time is 40 min. It has to be adjusted within the range 3 ... 300 min. The time check takes too long as several timing cycles would be necessary for a precise value.

For faster adjustment the setting is made to 0.03 ... 3 min. On this range the potentiometer should be set to 0.4 min. (= 24 sec). With the right potentiometer setting the LED must show 24 flashing cycles. After that the time range is switched over to 3 ... 300 min and the setting is complete.

Time interruption / Time adding

With the model MK7854N.82/500 the timing cycle can be interrupted by controlling input B1 (+) with control voltage. Removing the control signal will continue the timing cycle (time addition). When time interrupted the yellow LED stops to flash and goes to continuous light during pulse time (output relay active), or goes off during break time (output relay inactive).

Control input B1

The control input B1 (+) has to be supplied with voltage against A2. The control signal could be the same as the auxiliary/control voltage of A1 or any other voltage between 12 and 240 V AC or DC. Operating a parallel load between B1 and A2 is possible, which allows cost saving circuits.

Instantaneous contact

By external wire lings the output function for the variant MK 7854N.82/500 can be altered from 2 delayed contacts to 1 delayed and 1 instantaneous contact. The instantaneous contact switches when the operating voltage is connected.

To terminals X1 and X2 no other voltage potentials must be connected, as the unit might be damaged.

Notes

Remote potentiometers

With the variant MK 7854N.82/500 both time settings can also be made via remote potentiometers of 10 kOhms:

- Terminals Z1-Z2: potentiometer for pulse time (t_1)
- Terminals Z2-Z3: potentiometer for break time (t_2)

When connecting a remote potentiometer, the corresponding potentiometer has to be set to min. If no remote potentiometers are required the terminals Z1-Z2 resp. Z2-Z3 have to be linked.

The wires to the remote potentiometers should be installed separately from the lines with mains voltage. If this is not possible, a screened cable is recommended where the shield is connected to Z2.

To terminals Z1, Z2 and Z3 no external voltage must be connected, as the unit might be damaged.

Setting

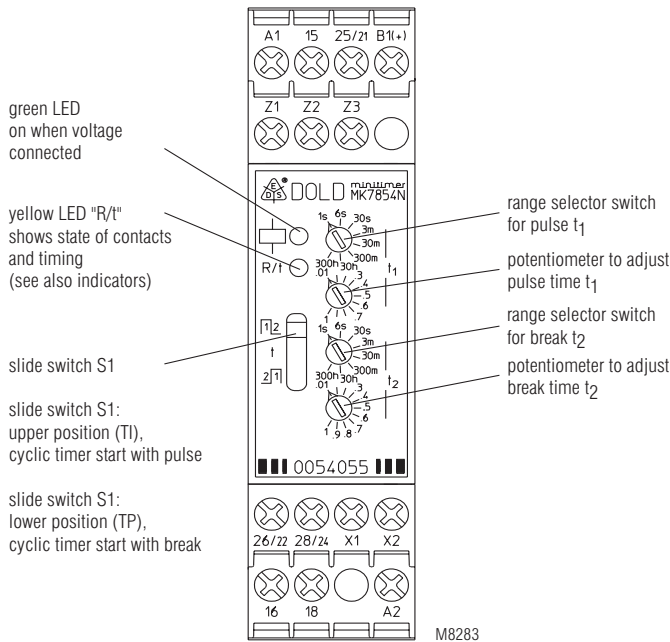

Technical data

Time circuit

| | |
|---------------------|---|
| Time ranges: | 8 time ranges for pulse and break time, settable via rotational switch: |
| | 0,05 ... 1 s 0,3 ... 30 min. |
| | 0,06 ... 6 s 3 ... 300 min. |
| | 0,3 ... 30 s 0,3 ... 30 h |
| | 0,03 ... 3 min. 3 ... 300 h |
| | continuous, 1:100 on relative scale |

Time setting t_1 , t_2 :

Recovery time:

| | |
|--------------|---------------|
| at DC 24 V: | approx. 15 ms |
| at DC 240 V: | approx. 50 ms |
| at AC 230 V: | approx. 80 ms |

Repeat accuracy:

± 0,5 % of selected end of scale value

Voltage and temperature influence:

< 1 % with the complete operating range

Input

| | |
|--|--------------------|
| Nominal voltage U_N: | AC/DC 12 ... 240 V |
| Voltage range: | 0,8 ... 1,1 U_N |
| Frequency range (AC): | 45 ... 400 Hz |
| Nominal consumption | |
| at AC 12 V: | approx. 1,5 VA |
| at AC 24 V: | approx. 2 VA |
| at AC 230 V: | approx. 3 VA |
| at DC 12 V: | approx. 1 W |
| at DC 24 V: | approx. 1 W |
| at DC 230 V: | approx. 1 W |

Technical Data

Release voltage (A1/A2)

| | |
|-----------|-----------------------------------|
| AC 50 Hz: | Delayed contact approx. 7,5 V |
| DC: | approx. 7 V |
| AC 50 Hz: | Instantaneous contact approx. 3 V |
| DC: | approx. 3,3 V |

Max. permitted residual current with 2-wire proximity sensor control (A1-A2)

| | |
|--------------------|------------------|
| up to AC/DC 150 V: | AC resp. DC 5 mA |
| up to AC/DC 264 V: | AC resp. DC 3 mA |

Control current (B1)

| | |
|------------------|---|
| MK 7854N.82/500: | approx. 1 mA, over complete voltage range |
|------------------|---|

Release voltage (B1/A2)

| | |
|-----------|---------------|
| AC 50 Hz: | approx. 3,5 V |
| DC: | approx. 3 V |

Output

Contacts:

| | |
|-----------------------|--|
| MK 7854N.82: | 2 changeover contacts |
| MK 7854N.82/500: | 2 changeover contacts, one programmable as instantaneous contact |
| without bridge X1-X2: | 25-26-28 delayed changeover contact |
| with bridge X1-X2: | 21-22-24 instantaneous contact at U_N on A1-A2 |

Thermal current I_{th} :

Switching capacity

| | | |
|-------------|----------------|-------------------|
| to AC 15 | | |
| NO contact: | 3 A / AC 230 V | IEC/EN 60 947-5-1 |
| NC contact: | 1 A / AC 230 V | IEC/EN 60 947-5-1 |
| to DC 13: | 1 A / DC 24 V | IEC/EN 60 947-5-1 |

Electrical life

at AC 15 to 1 A, AC 230 V: 1,5 x 10⁵ switching cycles

Permissible switching frequency:

36 000 switching cycles / h

Short circuit strength

max. fuse rating:

4 A gL IEC/EN 60 947-5-1

Mechanical life:

30 x 10⁶ switching cycles

General data

Operating mode:

Continuous operation

Temperature range:

- 20 ... + 60°C

Clearance and creepage distances

| | | |
|---|----------|--------------|
| overvoltage category / contamination level: | 4 kV / 2 | IEC 60 664-1 |
|---|----------|--------------|

EMC

| | | |
|--------------------------|------------|-------------------|
| Electrostatic discharge: | 8 kV (air) | IEC/EN 61 000-4-2 |
| Fast transients: | 2 kV | IEC/EN 61 000-4-4 |

Surge voltages

| | | |
|---------------------------------|------|-------------------|
| between wires for power supply: | 1 kV | IEC/EN 61 000-4-5 |
| HF-wire guided: | 10 V | IEC/EN 61 000-4-6 |

Degree of protection:

| | | |
|------------|-------|---------------|
| Housing: | IP 40 | IEC/EN 60 529 |
| Terminals: | IP 20 | IEC/EN 60 529 |

Housing:

Thermoplastic with V0 behaviour according to UL subject 94

Vibration resistance:

Amplitude 0,35 mm, frequency 10 ... 55 Hz, IEC/EN 60 068-2-6
20 / 060 / 04 IEC/EN 60 068-1

Climate resistance:

Terminal designation:

Wire connection:

EN 50 005
1 x 4 mm² solid or
1 x 2,5 mm² stranded wire with sleeve or
2 x 1,5 mm² stranded wire with sleeve
DIN 46 22-1/-2/-3/-4

Wire fixing:

Mounting:

Weight:

Box terminal with wire protection
DIN rail IEC/EN 60 715
150 g

Dimensions

| | |
|--------------------------------|-------------------|
| Width x height x depth: | 22,5 x 90 x 97 mm |
|--------------------------------|-------------------|

Standard type

MK 7854N.82 AC/DC 12 ... 240 V 0,05 s ... 300 h
 Article number: 0054053
 • Output: 2 changeover contacts
 • Nominal voltage U_N : AC/DC 12 ... 240 V
 • Time ranges: 0,05 s ... 300 h
 • Width: 22,5 mm

Variants

MK 7854N.82/500:

- Connection facility for 2 remote potentiometers 10kOhms to adjust pulse and break time
- 2 changeover contacts, one programmable as instantaneous contact
- Additional control input B1 for time interruption / time addition

Ordering example for variants

MK 7854N .82 / _ _ _ AC/DC 12 ... 240 V 0,05 s ... 300 h

Time range
 Nominal voltage
 Variant, if required
 Contacts
 Type

Accessories

AD 3:

External potentiometer 10 k Ω

The external potentiometer is used for remote setting of the time delay. The internal potentiometer of the timer must be set to min. time delay.

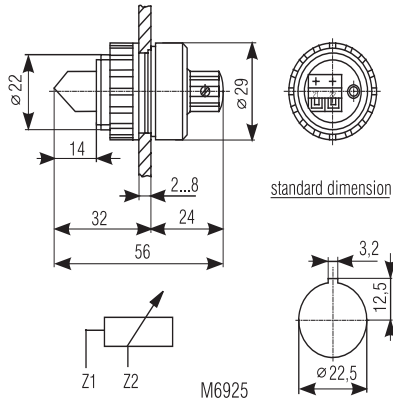

Connection examples

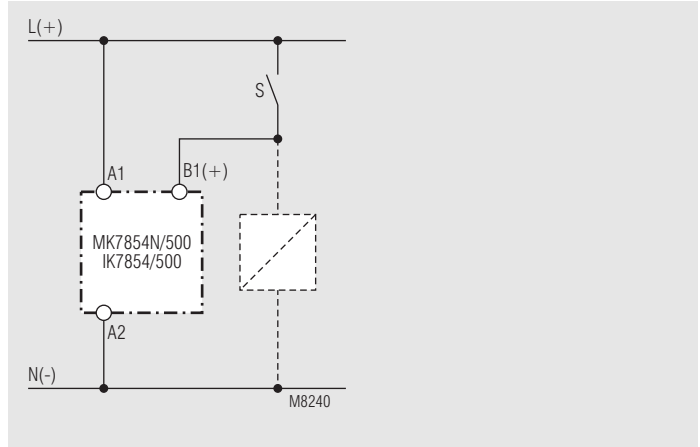
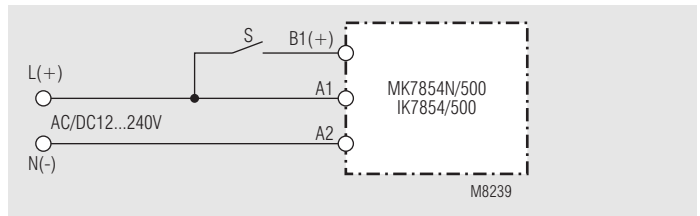

Control with parallel connected load

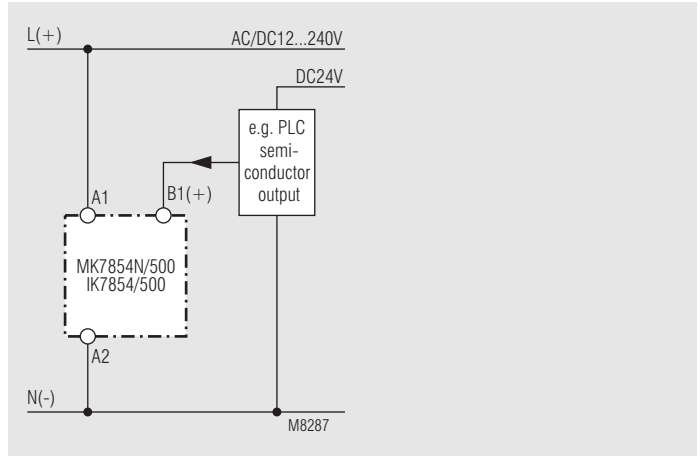

Connection with 2 different control voltages

Technical data

Time circuit

| | | |
|---------------------|--------------|----------------|
| Time ranges: | 0,05 ... 1 s | 0,5 ... 10 min |
| | 0,15 ... 3 s | 1,5 ... 30 min |
| | 0,5 ... 10 s | 3 ... 60 min |
| | 1,5 ... 30 s | 0,15 ... 3 h |
| | 3 ... 60 s | 0,5 ... 10 h |
| | 5 ... 100 s | 1,5 ... 30 h |
| | 15 ... 300 s | 5 ... 100 h |

Time setting: steppless on an absolute scale

Recovery time

tw 50 / 100: 40 ms

Repeat accuracy: $\leq \pm 0,5\%$ of the scale limit value

Voltage influence: $\leq 1\%$

Temperature influence: $< 0,1\%$ / K

Input

Nominal voltage U_N : AC/DC 24 V ¹⁾ + AC 110 ... 127 V ²⁾
AC/DC 24 V ¹⁾ + AC 230 ... 240 V ²⁾
also available as single-voltage version
AC/DC 12 V, AC/DC 42 ... 48 V

¹⁾ at terminals A3 - A2

²⁾ at terminals A1 - A2

Voltage range: AC 0,8 ... 1,1 U_N

DC 0,9 ... 1,25 U_N

Nominal consumption: AC 230 V DC 24 V DC 42 V

8,5 VA 1 W 1 W

Nominal frequency: 50 / 60 Hz

Frequency range: $\pm 5\%$ f_N

Resetting voltage: 15% U_N

Permissible residual current: 5 mA

Output

Contacts

MK 9906: 2 changeover contacts
MK 9906.32: 1 changeover contact, non-delayed

1 changeover contact, delayed

AA 9906.81: 1 changeover contact

AA 9906.82: 2 changeover contacts

Release time: 30 ms

Thermal current I_{th} : 5 A

Switching capacity

to AC 15

NO contact (MK 9906): 3 A / AC 230 V EN 60 947-5-1

NC contact (MK 9906): 2 A / AC 230 V EN 60 947-5-1

Electrical life EN 60 947-5-1

to AC 15 at 3 A, AC 230 V: 5 x 10⁵ switching cycles

Permissible switching frequency: 6 000 switching cycles / h

Short circuit strength

max. fuse rating: 6 A gL EN 60 947-5-1

Mechanical life: $> 30 \times 10^6$ switching cycles

General data

Operating mode: Continuous operation

Temperature range

MK 9906: - 20 ... + 60 °C

AA 9906: - 40 ... + 60 °C

Clearance and creepage distances

overvoltage category /

contamination level:

Input/output: 4 kV / 2 DIN VDE 0110-1 (4.97)

EMC

Electrostatic discharge: 8 kV (air) EN 61 000-4-2

HF irradiation: 10 V / m EN 61 000-4-3

Fast transients 4 kV EN 61 000-4-4

Surge voltages

between

wires for power supply: 1 kV EN 61 000-4-5

between wire and ground: 2 kV EN 61 000-4-5

HF-wire guided: 10 V EN 61 000-4-6

Interference suppression Limit value class B EN 55 011

Technical data

Degree of protection Housing: IP 40 EN 60 529

Terminals: IP 20 EN 60 529

Housing: Thermoplastic with V0 behaviour

according to UL subject 94

Vibration resistance: Amplitude 0,35 mm,

frequency 10 ... 55 Hz, EN 60 068-2-6

20 / 60 / 04 EN 60 068-1

Climate resistance:

Terminal designation: EN 50 005

Wire connection:

MK 9906: 2 x 1,5 mm² solid or

2 x 1,0 mm² stranded wire with sleeve

DIN 46 228-1/-2/-3/-4

AA 9906: 2 x 2,5 mm² solid or

2 x 1,5 mm² stranded wire with sleeve

DIN 46 228-1/-2/-3/-4

Wire fixing: Flat terminals with self-lifting

clamping piece EN 60 999

DIN rail EN 50 022

Mounting:

Weight

MK 9906: 140 g

AA 9906: 160 g

Ordering example

MK 9906 .82 / _ _ _ AC/DC 24 V + AC 230 ... 240 V 50 / 60 Hz 100 s



Dimensions

Width x height x depth

MK 9906: 22,5 x 82 x 99 mm

AA 9906: 45 x 77 x 127 mm

Accessories

for MK 9906:

ET 4752-143 marking plate

for AA 9906:

K 70-34 Cover



Figure 1 Timer AI 953 N

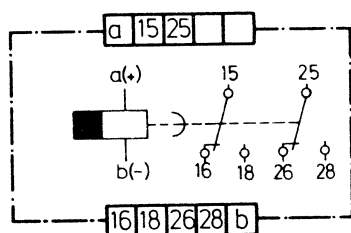

Figure 2

Design and working principle: Reliable circuit with switchproof electrolytic capacitors. Output: Robust industrial contactor with long service life and high switching capacity to VDE 0110 Class C for 250 V a.c./400 V d.c. Time setting is against absolute scale.

The service contacts are actuated immediately upon energization and the time capacitor is charged during the minimum make period. As soon as the energizing circuit is switched off, the time elapse begins and the service contact drops into the output position after elapse of the set delay. Due to the electrolytic capacitors used in the capacitor relay it is advisable to check the delay period and repeat the time cycle a number of times after a longer period of storage or non use, so that the dielectric in the electrolytic capacitors can form again.

Technical data:

Function: Release delay timer, without auxiliary voltage

Setting range: 0.05...1 sec 0.15...3 sec 0.3...6 sec

Setting: Infinitely variable external adjustment on absolute scale

Scatter: $\leq \pm 4\%$

Minimum make time: ≥ 250 ms 1 sec. range
 ≥ 500 ms other ranges

Important! Time error with minimum make period $< 10\%$. The error is reduced correspondingly with longer make periods.

Temperature influence: $< 0.5\%$ /°C

Voltage influence: $< \pm 30\%$

Nominal voltage: 42, 110, 220, 240 V a.c.
24 V d.c. residual ripple $\leq 10\%$
With pole protection

Voltage range: 80...110% of nominal voltage

Nominal frequency: 50...60 Hz

Nominal consumption: a.c. 3 VA d.c. 2.5 W

Temperature range: $-20...+60^\circ$ C

Contacts
AI 953 N.0082 2 changeover contacts, delayed

Type of contact: Spring contact

Response time of contacts: < 50 ms

Nominal breaking capacity:

| | | |
|------------------------|------------|------------|
| 24 V a.c. | 110 V a.c. | 220 V a.c. |
| 4 A | 4 A | 4 A |
| $\cos \varphi 1...0.7$ | 2.5 A | 2.5 A |
| $\cos \varphi 0.4$ | 24 V d.c. | 60 V d.c. |
| ohmic | 5 A | 1 A |
| inductive | 5 A | 0.8 A |
| | | 0.3 A |

Continuous current: 4 A

| | |
|--|---|
| Life expectancy, contacts: | 3 x 10 ⁶ operations 1500 operations/hour at 30 % rated capacity |
| | 1.5 x 10 ⁶ operations 1000 operations/hour at 50 % rated capacity |
| | 0.5 x 10 ⁶ operations 500 operations/hour at 100 % rated capacity |
| Admissible frequency of operations: | 3000 operations/hour |
| Life expectancy, mechanical: | 10 ⁷ operations |
| Creepage distances and air gap: | Group C, 250 V a.c., to VDE 0110 |
| Type of enclosure: | Case IP 50 Terminals IP 10 |
| Case: | Terminal board: Thermoplast PC DIN 7728 Case: Thermoplast ABS DIN 7728 |
| Terminal arrangement: | To DIN 46 199, Sheet 3 |
| Terminal coding: | To DIN 46 199, Sheet 1 and 2 |
| Lead connection: | Flat terminals with wire guard to VDE 0609 § 3e 1.3 |
| Net weight: | 0.260 kg |
| Example of an order: | Type Contacts Nominal voltage AI 953 N .0082 220 V 50 Hz Time range 0.05...1 sec |

Accessories

| | |
|--------------------|--|
| Flat plugs: | DIN 46 247, Sheet 1 and Sheet 2 Code letter "A" per connection 1 x 6.3 inclusive 2 x 2.8 Code letter "B" per connection 2 x 4.8 |
|--------------------|--|

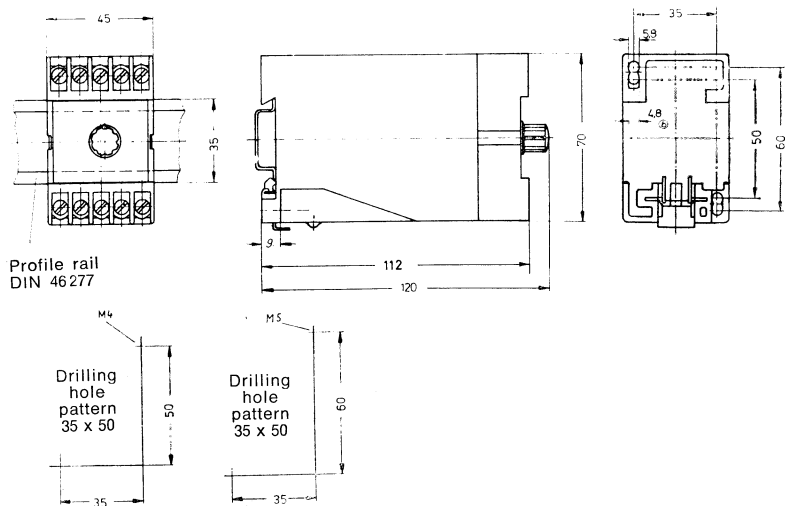

Figure 3 Measurement drawing

Time control technique

Timer AI 954 N, BA 7954, release delay minitimer



0227771



- According to DIN EN 61 812-1
- Delay up to 300 s
- Repeat accuracy $\lt; \pm 1 \%$
- Without auxiliary voltage
- for 2-wire proximity sensors
- With 1 or 2 changeover contacts
- Width 45 mm

Function diagram

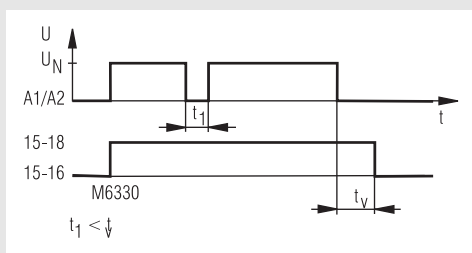

Circuit diagram

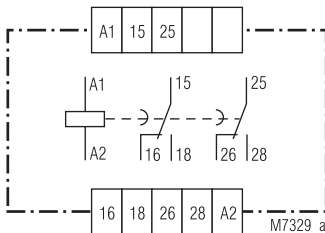

AI 954 N
BA 7954

Approvals and marking

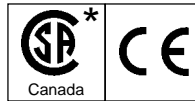

* see variants

Indication

LED: on when operating voltage applied

Standard types

| | | | | |
|---------------------------|--------------|------------|--------------|------------|
| AI 954N.82 | AC 230 V | 50 / 60 Hz | 0,5 ... 10 s | |
| Article number: | | | 0006562 | stock item |
| BA 7954.82 | AC 230 V | 50 / 60 Hz | 0,5 ... 10 s | |
| Article number: | | | 0024075 | stock item |
| • Nominal voltage U_N : | AC 230 V | | | |
| • Time range: | 0,5 ... 10 s | | | |

Variant

AI 954/60: with CSA-approval

Technical data

Time circuit

| | | |
|---------------------|--------------|--------------|
| Time ranges: | 0,05 ... 1 s | 0,15 ... 3 s |
| | 0,5 ... 10 s | 1,5 ... 30 s |
| | 5 ... 100 s | 15 ... 300 s |

Time setting: stepless, on absolute scale

Repeat accuracy: $\leq \pm 1 \%$

Min. setting time: 25 ms

Attention!

Time faults when min. setting time $\lt; 10 \%$. When setting time longer, the fault will be less.

Voltage influence: $\lt; \pm 1 \%$

Temperature influence $\lt; 0,3 \% / K$

Input

Nominal voltage U_N : AC 24, 42, 110, 127, 230, 240 V
DC 24 V

| | | | |
|------------|-----------|----------------|------|
| DC 48 V*: | ZWS 20 SL | 390 Ω | 20 W |
| DC 60 V*: | ZWS 20 SL | 640 Ω | 20 W |
| DC 110 V*: | ZWS 20 SL | 1,5 k Ω | 20 W |
| DC 220 V*: | ZWS 35 SL | 3,3 k Ω | 35 W |

*) with external series resistor

The series resistors have to be used together with DC 24 V-devices. The series resistor has to be connected to (+).

Voltage range: 0,8 ... 1,1 U_N

Permissible residual current: $\leq 2,5$ mA

Nominal consumption: AC 3 VA

| | | | |
|-------|-----|---------|--------|
| DC 48 | 60 | 110/127 | 220 V |
| 3,0 | 3,5 | 6,5 | 13,0 W |

Technical data

Nominal frequency: 50 / 60 Hz
Recovery time: ≥ 25 ms

Output

Contacts:

AI 954 N.0081, BA 7954.81: 1 changeover contact, delayed
AI 954 N.0082, BA 7954.82: 2 changeover contacts, delayed

Operate time of the contacts: ≤ 25 ms

Thermal current I_{th} : 5 A

Switching capacity

to AC 15:

NO contact: 3 A / AC 230 V EN 60 947-5-1

NC contact: 1 A / AC 230 V EN 60 947-5-1

Electrical life EN 60 947-5-1

to AC 15 at 1 A, AC 230 V: 2,5 x 10⁵ switching cycles

Permissible switching

frequency: 6000 switching cycles / h

Short-circuit strength

max. fuse rating: 4 A gL EN 60 947-5-1

Mechanical life: > 10 x 10⁶ switching cycles

General data

Operating mode: Continuous operation

Temperature range: - 20 ... + 60 °C

Clearance and creepage

distances

overvoltage category /

contamination level: 4 kV / 2 DIN VDE 0110-1 (04.97)

EMC

Electrostatic discharge: 8 kV (air) EN 61 000-4-2

HF irradiation: 10 V/m EN 61 000-4-3

Fast transients: 2 kV EN 61 000-4-4

Surge voltages

between

wires for power supply: 1 kV EN 61 000-4-5

between wire and ground: 2 kV EN 61 000-4-5

Interference suppression: Limit value class B EN 55 011

Degree of protection: Housing: IP 40 EN 60 529

Terminals: IP 20 EN 60 529

Housing:

Thermoplast with V0 behaviour

according to UL subject 94

Vibration resistance: Amplitude 0,35 mm

frequency 10 ... 55 Hz EN 60 068-2-6

Climate resistance: 20 / 60 / 04 EN 60 068-1

Terminal arrangement: DIN 46 199-5

Terminal designation: EN 50 005

Wire connection: 2 x 2,5 mm² solid or

2 x 1,5 mm² stranded wire with sleeve

DIN 46 288-1/-2/-3/-4

Wire fixing: Flat terminals with self-lifting

clamping piece EN 60 999

Mounting: DIN rail EN 50 022

Weight: 260 g

Ordering example

AI 954 N .0082 AC 230 V 50 / 60 Hz 100 s

Time range max. value
Nominal frequency
Nominal voltage
Contacts
Type

Dimensions

Width x height x depth

AI 954N: 45 x 77 x 127 mm

BA 7954: 45 x 73 x 133 mm

Accessories

ZWS 20 SL, ZWS 35 SL:

Series resistors

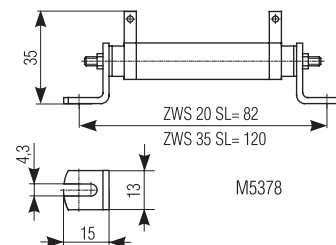

for AI 954 N:
K 70-34

Transparent cover

for BA 7954:
ET 4762-5

Adaptor

0226785

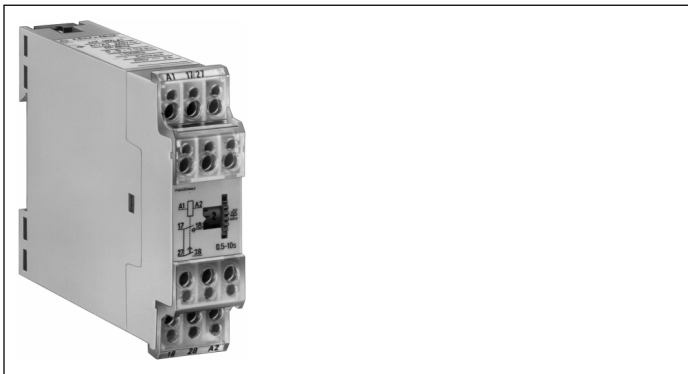

- According to DIN EN 61 812-1
- Time delay up to 100 s
- Repeat accuracy $< \pm 0,5 \%$
- Dual-voltage version
- Available with UL- or CSA approval
- Width 22,5 mm

Function diagram

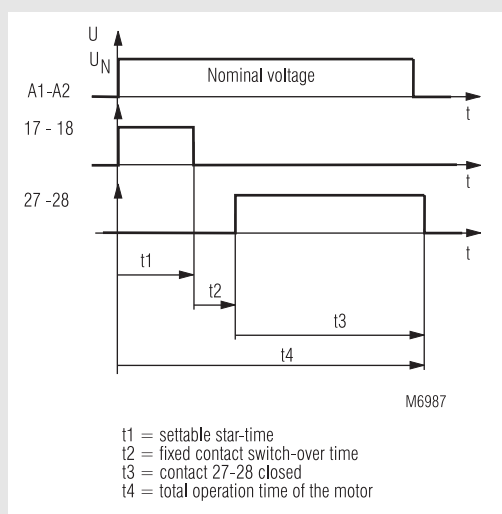

Circuit diagram

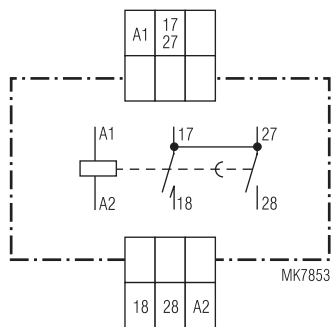

MK 7853/024

Approvals and marking

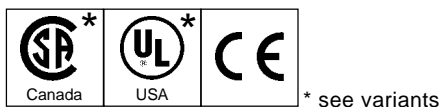

Applications

Star-delta-starting circuit for squirrel cage motors

Function

The MK 7853/024 is a static star-delta-timer with 2 separate output relays. As soon as the operating voltage is applied, relay 1 will be energized and falls back after time delay. After elapse of the contact changeover time, the second relay switches on and remains in active position, as long as the star-delta-timer is energised.

Variants

- MK 7853/60: with CSA-approval
 MK 7853/61: with UL-approval

Technical data

Time circuit

- Time ranges:** 0,5 ... 10 s 1,5 ... 30 s
 3,0 ... 60 s 5,0 ... 100 s
- Contact changeover time:** approx. 100 ms
 approx. 35 ms
 please state when ordering
 stepless on absolute scale
- Time setting:**
Recovery time
 tw 50 / 100: 40 ms
- Repeat accuracy:** $\leq \pm 0,5 \%$ of the max. scale value
- Voltage influence:** $\leq 1 \%$
- Temperature influence:** 0,1 % / K

Input

- Nominal voltage U_N :** AC/DC 24 V¹⁾ + AC/DC 42 V²⁾
 AC/DC 24 V¹⁾ + AC 110 ... 127 V²⁾
 AC/DC 24 V¹⁾ + AC 220 ... 240 V²⁾
 AC/DC 24 V¹⁾ + AC 400 V²⁾
¹⁾ at terminals A3-A2
²⁾ at terminals A1-A2
- Voltage range:** 0,8 ... 1,1 U_N
- Nominal consumption:** AC 230 V 7 VA AC/DC 24 V 0,6 W
- Nominal frequency:** 50 / 60 Hz
- Frequency range:** $\pm 5 \%$ f_N

Output

- Contacts:** 1 fleeting on make
 1 NO contact delay on
- Release time:** 40 ms
- Thermal current I_{th} :** 5 A

Technical data

Switching capacity

to AC 15:

NO contact: 3 A / AC 230 V DIN VDE 0660 p. 200

NC contact: 2 A / AC 230 V DIN VDE 0660 p. 200

Electrical life DIN VDE 0660 p. 200

to AC 15 at 3 A, AC 230 V: 5 x 10⁵ switching cycles

Permissible switching frequency:

6 000 switching cycles / h

Short-circuit strength

max. fuse rating: 4 A gL DIN VDE 0660

Mechanical life: 20 x 10⁶ switching cycles

General data

Operating mode

Continuous operation

Temperature range:

- 20 ... + 60 °C

Clearance and creepage distances

overvoltage category /
contamination level:

4 kV / 2 DIN VDE 0110-1 (4.97)

EMC

Electrostatic discharge: 8 kV (air) EN 61 000-4-2

HF irradiation: 10 V/m EN 61 000-4-3

Fast transients: 2 kV EN 61 000-4-4

Surge voltages: 1 kV EN 61 000-4-5

Interference suppression: Limit value class B EN 55 011

Degree of protection: Housing: IP 40 DIN VDE 0470-1

Terminals: IP 20 DIN VDE 0470-1

Housing:

Thermoplastic with V0 behaviour
according with UL Subj. 94

Vibration resistance:

Amplitude 0,35 mm
frequency 10 ... 55 Hz IEC 68-2-6

20 / 60 / 04 DIN EN 60 068-1

Climate resistance:

Terminal designation:

EN 50 005

Wire connection:

2 x 1,5 mm² solid or
2 x 1,0 mm² stranded wire with sleeve
DIN 46 288-1/-2/-3/-4

Wire fixing:

Flat terminals with self-lifting
clamping piece DIN 46 206 and
DIN 57 609 / VDE 0609

Mounting:

DIN rail DIN EN 50 022

Weight:

130 g

Ordering example

MK 7853/024 100 s / 35 ms AC/DC 24 V + AC 220 ... 240 V

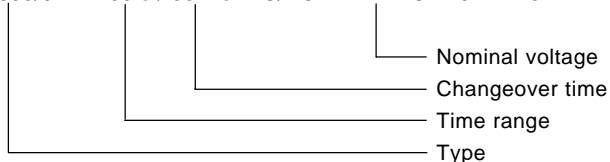

Dimensions

Width x height x depth: 22,5 x 82 x 99 mm

Accessories

ET 4752-143: marking plate

Connecting example

